

The next activities are solitaire puzzles. You will need up to 7 pebbles. Put 1 pebble in each circle except for the circle marked E (empty). Then start jumping 1 pebble over another, into an empty circle. Take away each pebble you jump over. Try to end up with only 1 pebble.

1.

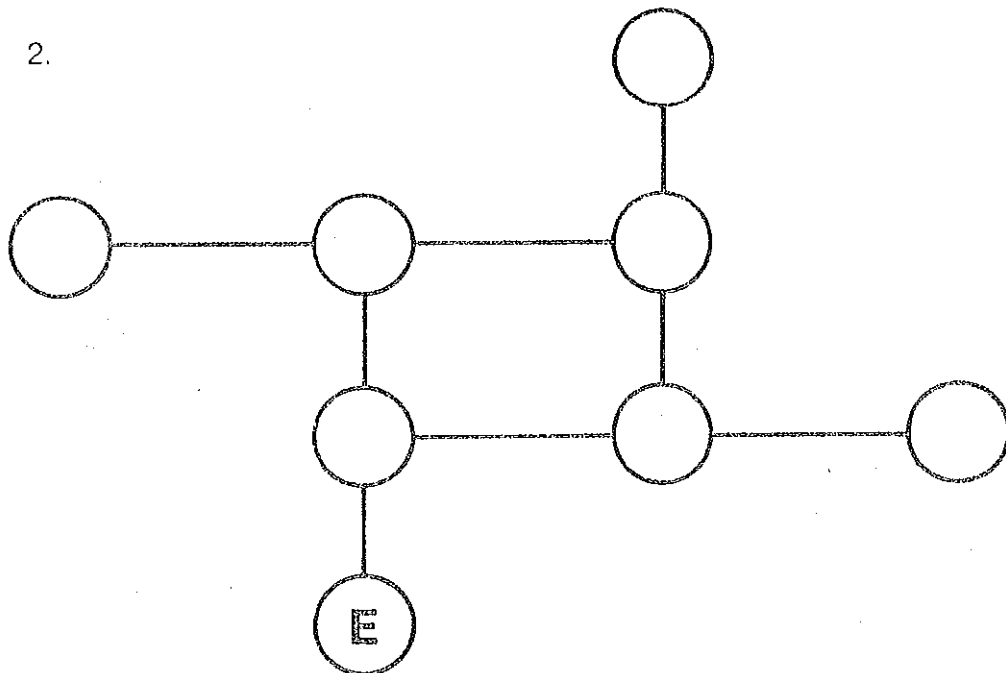

2.



3.



Use up to 10 pebbles for these solitaire puzzles. Start with 1 pebble in each circle except for the circle marked E. Jump 1 pebble over another, into empty circles. Take away each pebble you jump over. Try to end up with just 1 pebble.

1.

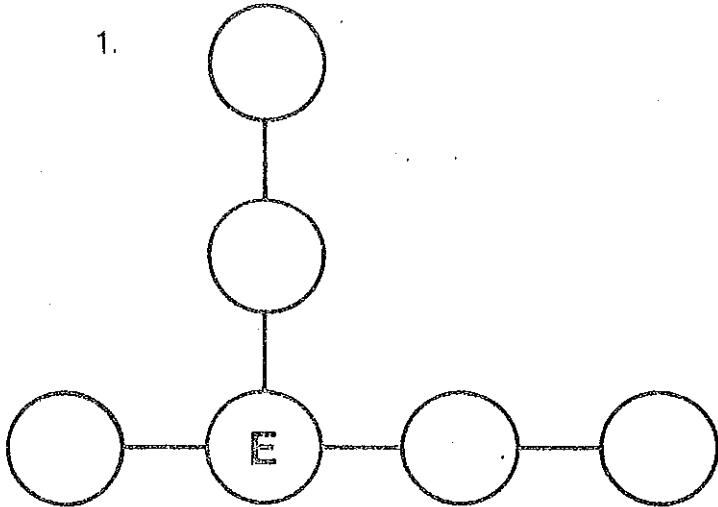

2.

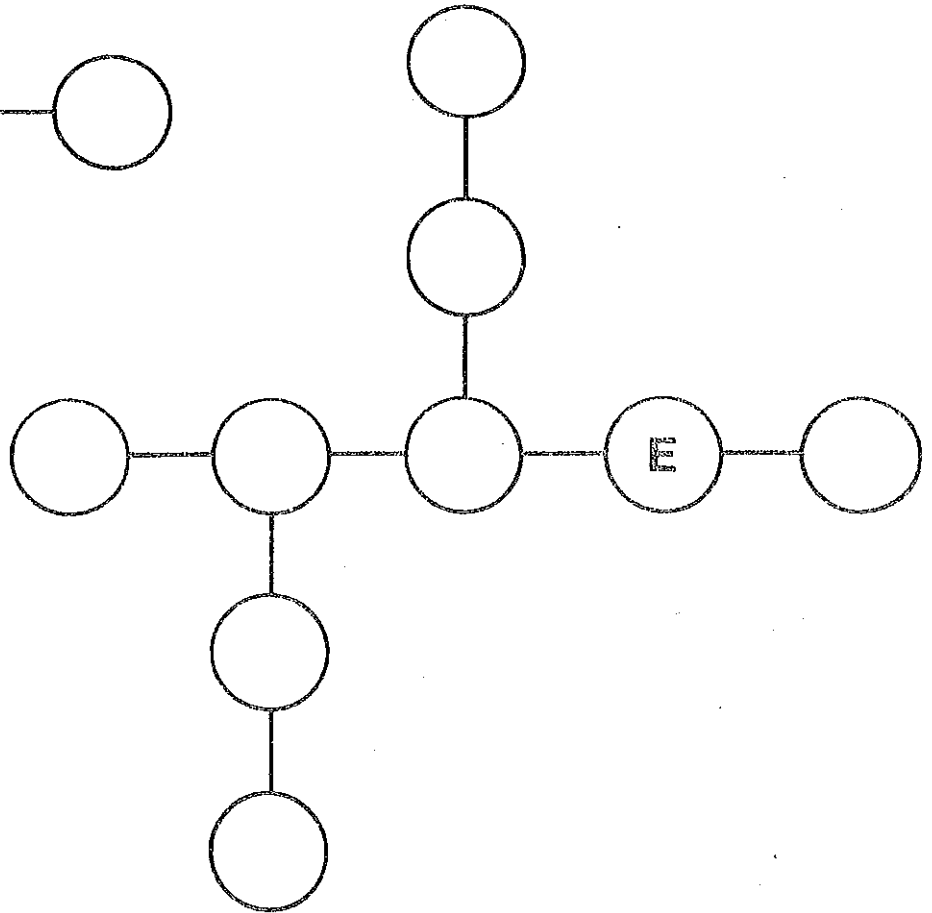

3.

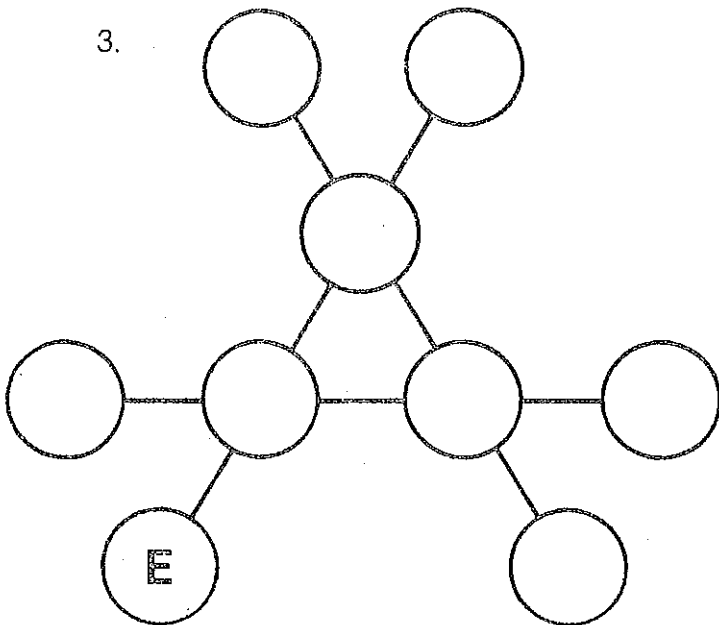

Use up to 10 pebbles for these solitaire puzzles. Start with 1 pebble in each circle except for the circle marked E. Jump 1 pebble over another, into empty circles. Take away each pebble you jump over. Try to end up with just 1 pebble.

1.

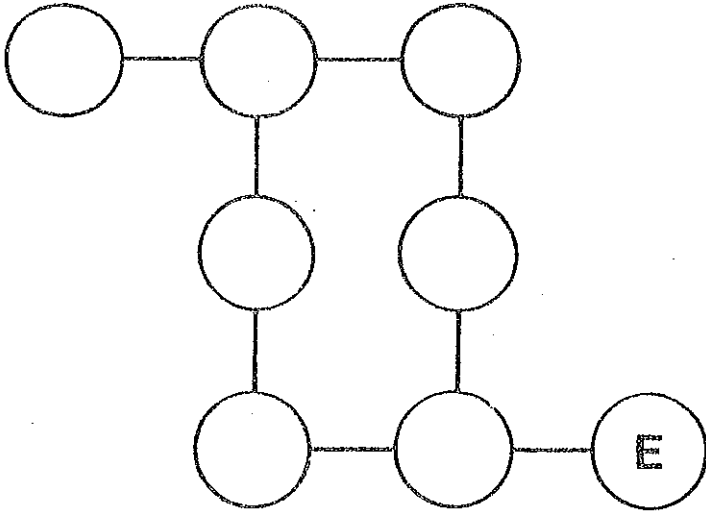

2.

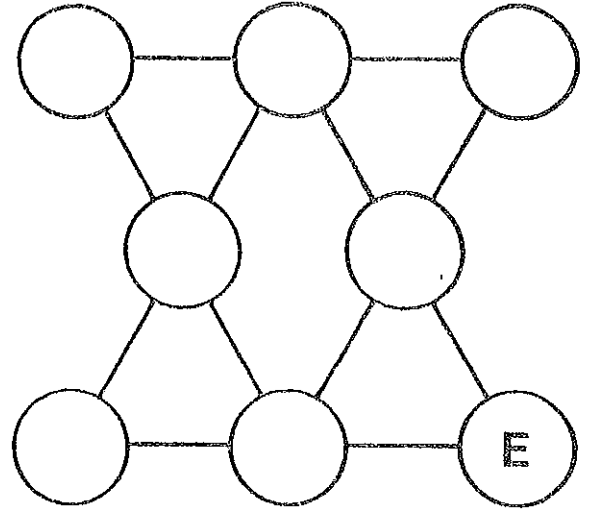

3.

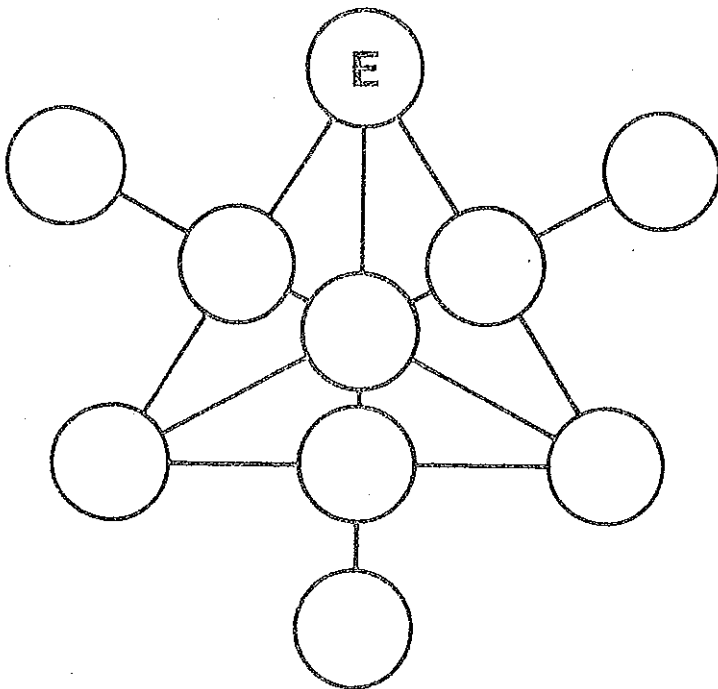

4.

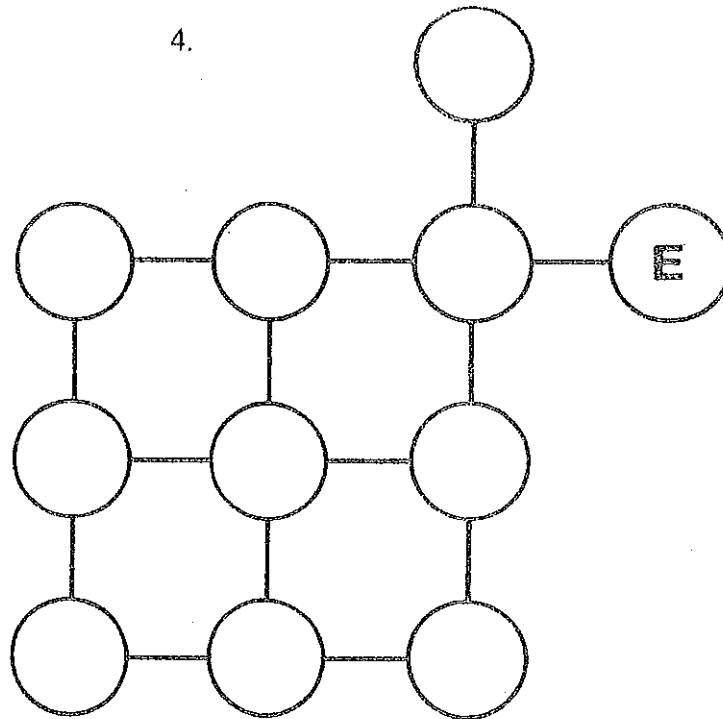

Use up to 12 pebbles for these puzzles. Start with 1 pebble in each circle except for the circle marked E. Jump 1 pebble over another, into empty circles. Take away each pebble you jump over. Try to end up with just 1 pebble.

1.

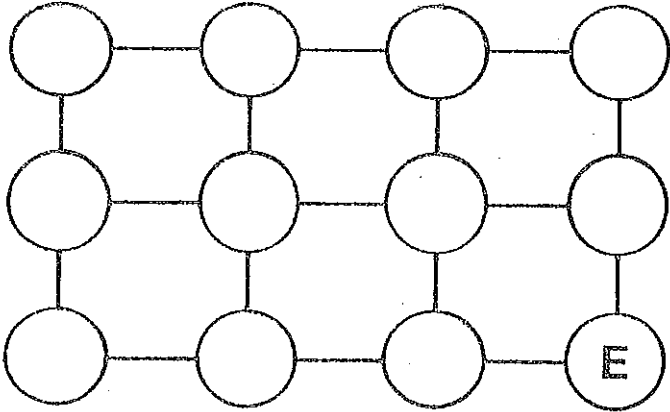

2.

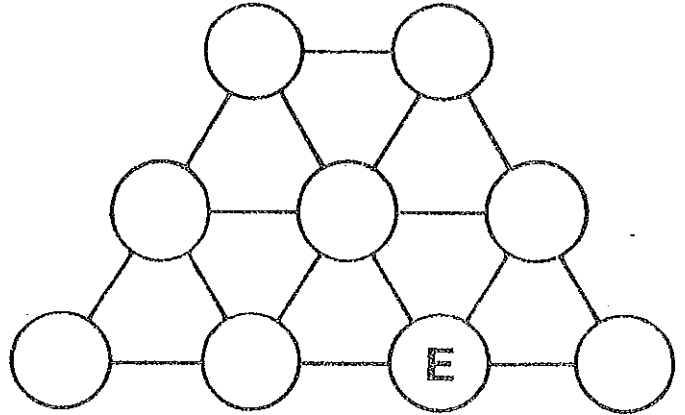

3.

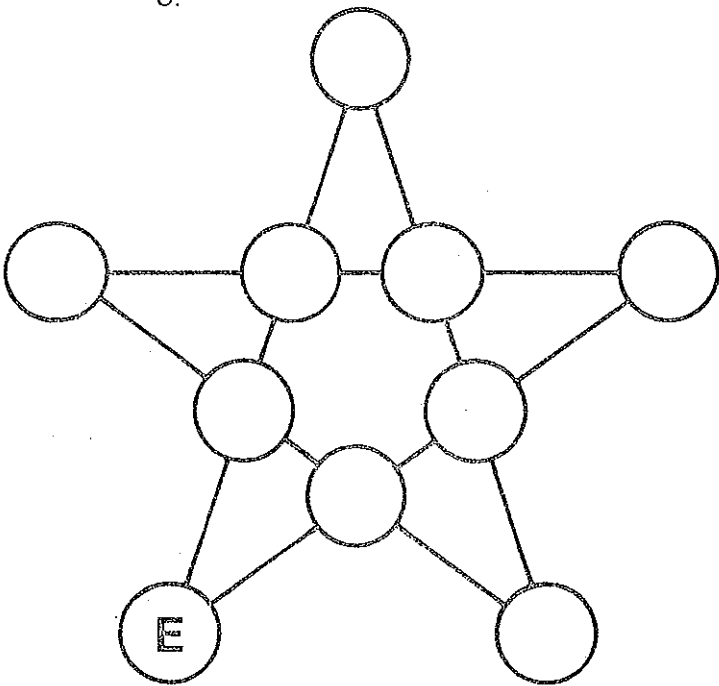

4.

